

Please read and save these instructions. Read carefully before attempting to assemble, install, operate or maintain the product described. Protect yourself and others by observing all safety information. Failure to comply with instructions could result in personal injury and/or property damage! Retain instructions for future reference.

Action Barrel Pumps

Description

Action hand-operated barrel pumps will deliver between three and four gallons of liquid per minute depending on your specific model. The bung adapter fits standard 2" threaded openings in 15, 30 and 55 gallon barrels and drums. Models 1460 and THP-M barrel pumps have chrome plated steel body and polyethylene internal parts. They are used for pumping chemicals compatible with steel and polyethylene. Models 316T and THP-S barrel pumps have type 316 stainless steel body and Teflon internal parts. They are used for pumping some acids, solvents, paint thinners and other chemicals compatible with 316 stainless and Teflon.

Specifications

	1460	316T	THP-M	THP-S
Flow rate per stroke	.8 oz.	.8 oz.	.16 oz.	.16oz.
Mounting	See Bung	See Bung	See Bung	See Bung
Inlet		1/2"	1/2"	1-1/2" 1-1/2"
Outlet		1/2"	1/2"	3/4" 3/4"
Bung Adapter	.2" Delrin	.2" Delrin	.2" (PE)	.2" (PE)
Suction Tube				
(Length & Material)	.22" (PE)	.22" Teflon	.37" Steel	.37" SS
Packing Gland	PE	PE	Teflon	Teflon
Wetted Parts	PE & PP	PE & PP	Steel, PE & Teflon	316SS, Teflon
SSU	.90 Weight Oil @ 72°F	.90 Weight Oil @ 70°	.90 Weight Oil @72°	.90 Weight Oil @ 72°
Max. Temp.	140°F	140°F	140°	140°

General Safety Information

⚠ WARNING *It is the responsibility of the user to operate the pump in conformance with OSHA rules for dispensing liquids. Pump containers should be grounded when using with flammable liquids to avoid static electricity. Pump should be washed out before usage since processing lubricants could contaminate fluids.*

- When using a hand pump (especially when pumping flammable, combustible or hazardous liquids) follow all electrical and safety codes, as well as the United States Occupational Safety and Health Act

(OSHA), most recent National Electrical Code (NEC), National Fire Protection, Inc. * (NFPA) Code 30 (Flammable and Combustible Code), NFPA 56A (Standard for use of Inhalation Anesthetics), NFPA 77 (Static Electricity), NFPA 78 (Lightning Protection Code), NFPA 80 (Standard for Fire Doors and Windows), NFPA 251 (Standard Method of fire Test of Building Construction), NFPA 704 (Identification of the Fire Hazards of Materials), other NFPA codes, local codes and ordinances, as needed in a particular application

- Know the pump application, limitations, and potential hazards.

The "WARNING" statements indicate potential hazardous conditions for the operator or equipment. TAKE NECESSARY STEPS TO PROTECT PERSONNEL AND EQUIPMENT.

NOTE: Pump should only be used with liquids compatible with pump component materials. Consult PUMP CHEMICAL COMPATIBILITY CHART and PUMP SPECIFICATIONS. Also, the chemical supplier should be consulted regarding any questions of chemical compatibility, proper and safe use and handling of chemical. Misapplication of pump or use of non-compatible liquids will void warranty.

Action Barrel Pumps

▲ WARNING *In order to properly use this product, familiarize yourself with this pump and also with the liquid (chemical, etc.) that is going to be pumped through this unit. Although this pump is suitable for many liquids it is NOT suitable for all liquids!*

(*) Any of the NFPA Codes can be obtained from : National Fire Protection Association, Inc., Batterymarch Park, Quincy, MA 0269, telephone 1-800-344-3555. Write or call for listing and prices.

3. Pumping hazardous, flammable, or combustible liquids should only be done in buildings, rooms, or areas suited for this purpose. (See NFPA 30, NFPA 78, NFPA 80, NFPA 251, NFPA 704, other suitable NFPA codes, OSHA, insurance companies, local codes and ordinances.)

▲ WARNING *When filling cans, drums, etc. with combustible or flammable liquids, both container pumping from and container pumping to, should be bonded and grounded to dissipate possible accumulations of static electricity, and minimize sparks caused by static electricity (refer to NFPA 77 for specifics and further details).*

Removal of outer garments in work areas where there may be flammable or explosive liquids, which are ignitable with low electrical energy, can be fatal and/or cause property damage (refer to NFPA 56A, and NFPA 77, for further details).

4. The "WARNING" and instructions for gasoline below pertain not only to gasoline, but to any flammable, combustible or hazardous fluid.

▲ WARNING *Gasoline is a highly flammable fuel. The improper use, handling or storage of gasoline can be dangerous. Prevent accidents by following these safety rules:*

- a. Use gasoline only as a fuel, never as a cleaning fluid.
 - b. Use only an approved container to hold or store gasoline. Never store gasoline in familiar containers such as milk containers or soda pop bottles.
 - c. Store gasoline in a cool location, out of the reach of children. Never store gasoline near heat or an open flame.
 - d. Provide a fire extinguisher nearby when working with gasoline. Be sure extinguisher is in operating condition — check the pressure gauge or indicator. Be familiar with its proper use. Consult local fire department for the correct type of extinguisher for your application. Extinguishers rated ABC by the National Fire Protection Association are appropriate for most applications.
 - e. Provide positive shut-off valves on all permanent fuel supplies. Fuel lines must be of steel piping, adequately secured, and free from leaks.
 - f. Provide adequate ventilation, and clean up any spills when handling or pumping flammable liquids.
 - g. POSITIVELY NO SMOKING!
5. Do not use torches or apply fire or flame to this pump for any reason.
 6. Secure the discharge line before starting the pump. An unsecured discharge line will slip, possibly causing personal injury and/or property damage.
 7. Do not over tighten nonmetallic threaded fittings. One full turn past hand tight is usually enough to prevent leakage. Teflon sealant tape should be used on all threaded joints, including the spout.
 8. Check hoses for weak or worn condition before each use, making certain that all connections are secure.
 9. Periodically inspect pump and system components. Perform routine maintenance as required
 10. Drain all liquids from the system before servicing.

▲ WARNING *Any pump used to transfer flammable liquids must be stored in a well ventilated area after use.*

11. Personal Safety

- a. Wear safety glasses at all times when working with pump.
- b. Wear a face shield, proper apparel and suitable respiratory equipment, when pumping hazardous chemicals.
- c. Keep work area clean, uncluttered, and properly lighted, replace all unused tools and equipment.
- d. Keep visitors at a safe distance from the work area.
- e. Make workshop childproof, with padlocks, master switches, and by removing starter keys.

▲ WARNING *Failure to follow all general safety information can result in a fatality, personal injury and/or property damage!*

Installation THP-M & THP-S

1. Check to see if all parts are present.
2. Install discharge spout (13) making sure that the O-ring (11) is installed. Tighten firmly making sure discharge spout is secure.
3. Remove bung adapter (16) and install on pump body (17) with threaded end down.

Models 1460, 316T, THP-M and THP-S

Installation (Continued) THP-M AND THP-S (CONTINUED)

4. Insert pump assembly into 2" opening of 55 gallon drum and screw adapter clockwise into drum.
5. Adjust pump to desired height and tighten thumb screw in adapter by hand. DO NOT USE WRENCH OR TOOL TO TIGHTEN THUMB SCREW.

1460 & 316T

1. Remove bung adapter (12) and install on pump body (10) with threaded end down.
- 2 Attach hose (1) opposite angled end, and push onto nipple of end plug (13).

3. Insert pump assembly into 2" opening of 55 gallon drum and screw adapter clockwise into drum.
4. Adjust pump to desired height and tighten thumb screw in adapter by hand. DO NOT USE WRENCH OR TOOL TO TIGHTEN THUMB SCREW.

Operation

1. The pump is now ready for operation. Liquids should begin flowing on second or third upstroke. If slight leakage should occur, simply tighten packing nut (Ref. No. 2) on top of pump.

NOTE: Tighten only enough to prevent leakage. Excessive tightening will

damage the packing and cause more leakage.

2. If pump is removed from drum, rinse thoroughly in liquid that is compatible with both the pump and fluid. For questions about chemical compatibility, contact your chemical supplier.

Maintenance

Normal maintenance is not required. If models 1460 or 316T leaks at the top, tighten or replace packing gland (7) and/or gasket (9). If models THP-M or THP-S leaks at the top, replace packing gland (4) or at the spout, O-ring (11).

90-Day Limited Warranty

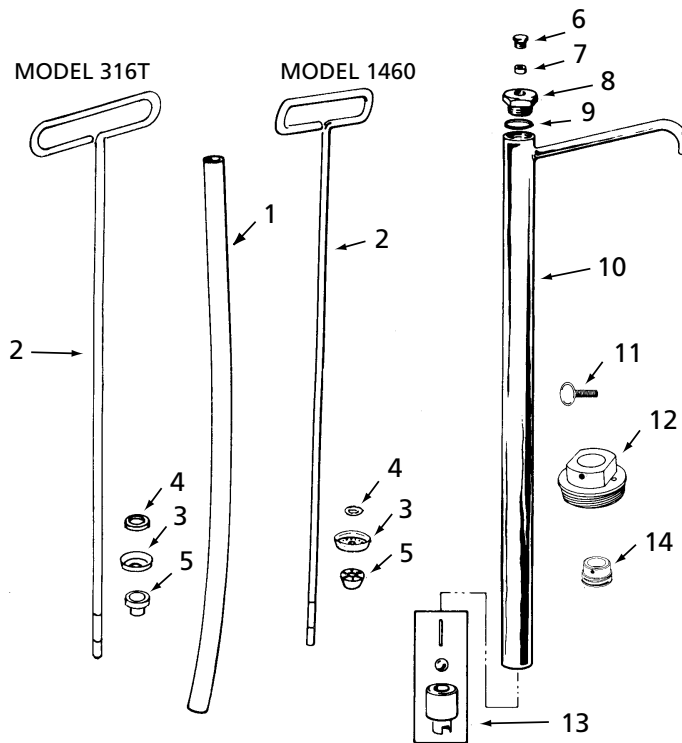

Figure 1 — Replacement Parts Illustration for Models 1460 and 316T

Replacement Parts List for Model 1460 and 316T

Reference Number	Description	Material	1460 Part Number	Material	316T Part Number	Quantity
1	† Hose	Polyethylene	1650-16	Teflon	2005-16	1
2	†▲ Handle & Piston Rod	Steel	1650-7P	316SS	2005-7P	1
3	●†▲ Piston	Polyethylene	—	Teflon	—	1
4	●†▲ Piston Washer	Steel	—	Steel	—	1
5	●†▲ Push On Nut	Steel/Polyethylene	—	316SS	—	1
6	†▲ Packing nut	Steel	1650-3P	316SS	2005-3P	1
7	●†▲ Packing gland	Polyethylene	—	Teflon	—	1
8	†▲ Body head	Steel	1650-2P	316SS	2005-2P	1
9	●†▲ Gasket	Neoprene	—	Teflon	—	1
10	† Body Assembly	Steel	1650-1C	316SS	2005-1C	1
11	Thumb screw	Steel	1650-19	Steel	1650-19	1
12	Bung adapter	Delrin	1650-25	Delrin	1650-25	1
13	†▲ End plug adapter	Steel/Glass	1650-DP	316SS/Teflon	2005-DP	1
14	‡ 5-Gallon Pail Adapter	Steel	134	Steel	134	1
	Handle & Piston Rod Assembly (Includes Ref. Nos. 2 thru 9)	—	1650-S	—	2005-S	1
	● Repair Kit	—	1460R1	—	316TR1	
	‡▲ 5 Gallon Pail Flexispout	Polyethylene	258	Polyethylene	258	1
	‡▲ 2" Buttress for 55 Gallon Drums	Polyethylene	3005-25	Polyethylene	3005-25	

(†) Wetted Parts. (▲) Not Shown. (‡) Optional.

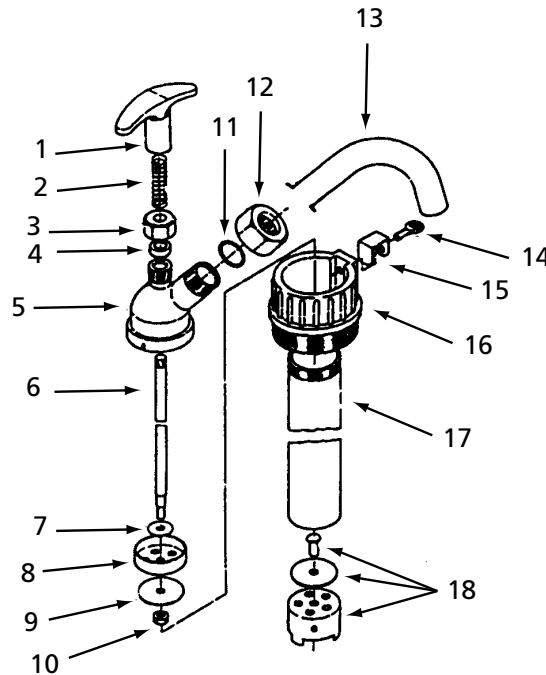

Figure 2 — Replacement Parts Illustration for Models THP-M and THP-S

Replacement Parts List for Models THP-M and THP-S

Reference Number	Description	THP-M		THP-S		Quantity
		Material	Part Number	Material	Part Number	
1	Handle	Nylon	433-10	Nylon	434-10	1
2	Spring	Steel	433-29	Steel	434-29	1
3	Packing nut	Steel	433-06	Steel	434-06	1
4	†▲ Packing gland	Teflon	433-07	Teflon	434-07	1
5	† Body Head	Steel	433-42	S.S.	434-42	1
6	† Inner shaft	Steel	433-48	S.S.	434-48	1
7	† Washer	Steel	433-49	S.S.	434-49	1
8	†▲ Piston	PE	433-52	Teflon	434-52	1
9	† Piston washer	Steel	433-50	S.S.	434-50	1
10	† Hex nut	Steel	433-40	S.S.	434-40	1
11	†▲ O-ring	Neoprene	433-04	Teflon	434-04	1
12	Spout nut	Steel	433-03	S.S.	434-03	1
13	† Discharge spout	Steel	433-45	S.S.	434-45	1
14	Thumb Screw	Steel	433-19	Steel	434-19	1
15	Clip	Steel	433-17	Steel	434-17	1
16	Bung Adapter	Polyphenylene	433-15	Polyphenylene	433-15	1
17	† Outer Body	Steel	433-41	S.S.	434-14	1
18	† End plug assembly	Steel	433-18	S.S.	434-18	1

For Buttress adapter for 55 barrel drums, order Part No. 3005-25.

(†) Wetted parts

(▲) Repair kit: For Model THP-M order 433-RK. For Model THP-S order 434-RK.

